



FR-30 Centrifugal Feeder

Designed for Quiet, High Speed Feeding



Product Overview:

Hoppmann's standard FR-30 feeds and orients a wide variety of parts utilizing a stationary loading ramp and the product's natural weight bias. The delivery rate varies from moderate to high speed depending on part characteristics. Its solid urethane bowl lends itself to machining for product profiling and those unique part feeding applications making the FR-30 a truly versatile and tailor-made feeding base.

Product Specifications:

	<u>ANSI</u>	<u>Metric</u>
A. Outer Wall Diameter	40.50"	1029mm
B. Overall Height	26.25" ± 1"	667mm ±25mm
C. Discharge Height	18.5"	470mm
D. Bowl Outside Diameter	36.13"	918mm
E. Rim Width	3.63"	92mm

Standard Models:

Part Number	<u>FR30XXDSA</u>	<u>FR30XXASA</u>
Motor Style	DC	AC
Motor Voltage	90V	240V
Horsepower	1/8 hp	93 W
Total Equipment Weight	350 lbs.	159 kg

Standard Features:

- All stainless steel construction
- Cast urethane bowl
- Panel mount controller card

Available Options:

- Air ramp
- Polycarbonate covers
- Dual motor drive system
- Washdown motor(s)
- NEMA 1 encased controller

Required Accessories:

	<u>CW</u>	<u>CCW</u>
Air Ramp	ARCWFR30SU	ARCCFR30SU
Square Frame		
Backup Ring	BUCWFR30SU	BUCCFR30SU

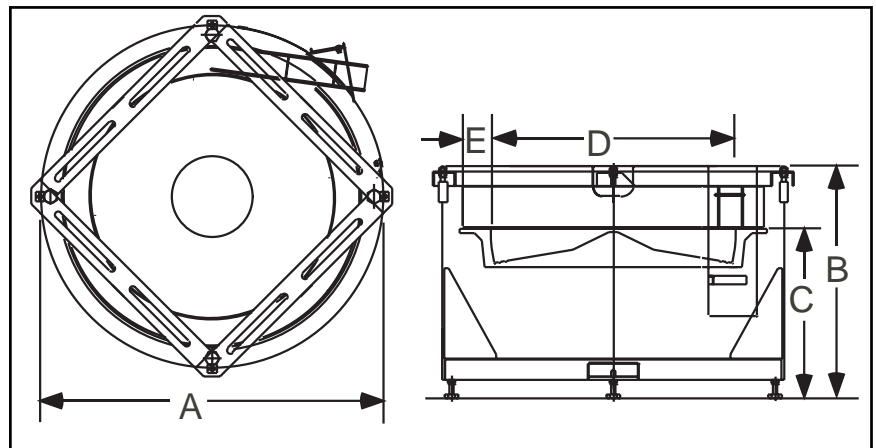

Hoppmann Corporation strives to improve its products and reserves the right to change or discontinue specifications & designs shown in this brochure without notice and without incurring obligation. 06/05

We Can Handle It.

Your Local Representative:

Automatic Feeder Company Inc.
 921 Albion Avenue Schaumburg, IL 60193-4550
 Phone: (847) 534-2300 Toll-Free: (888) 534-2340 Fax: (847) 534-2354
 www.automaticfeeder.com Email: sales@automaticfeeder.com

