



## FRS-60 Centrifugal Feeder

*Designed for Quiet, High Speed Feeding*



**Product Overview:**

Hoppmann's standard FRS-60 is specifically designed to feed a wide range of large bottles and parts. The delivery rate varies from moderate to high speed depending on part characteristics. The FRS-60 is engineered to interface with Hoppmann prefeeders, accumulating conveyors, assembly systems and other downstream equipment.

**Product Specifications:**

	<u>ANSI</u>	<u>Metric</u>
A. Overall Width at Exit Zone	85"	2159mm
B. Overall Width	82"	2083mm
C. Overall Height	66" ± 5"	1676 ± 127mm
D. Discharge Height	40" ± 5"	1016 ± 127mm
E. Bowl Inside Diameter	51.79"	1315mm
F. Rim Width	8"	203mm
G. Scallop Length	12"	305mm

**Standard Models:**

	<u>RS60XXXDSA</u>	<u>RS60XXXASA</u>
Part Number	DC	AC
Motor Style	90V	220/380V
Motor Voltage	3/4 hp	560 W
Horsepower	2500lbs	1134 kg
Weight Untooled		

**Standard Features:**

- Aluminum bowl with stainless steel walls
- Stainless steel cover
- Air clutch
- Backup ring
- Panel mount controller card

**Available Options:**

- Washdown motor
- Urethane scallop kit
- NEMA 1 encased controller

**Required Accessories:**

FRS Series Scallop Kit ..... URTHCAST64

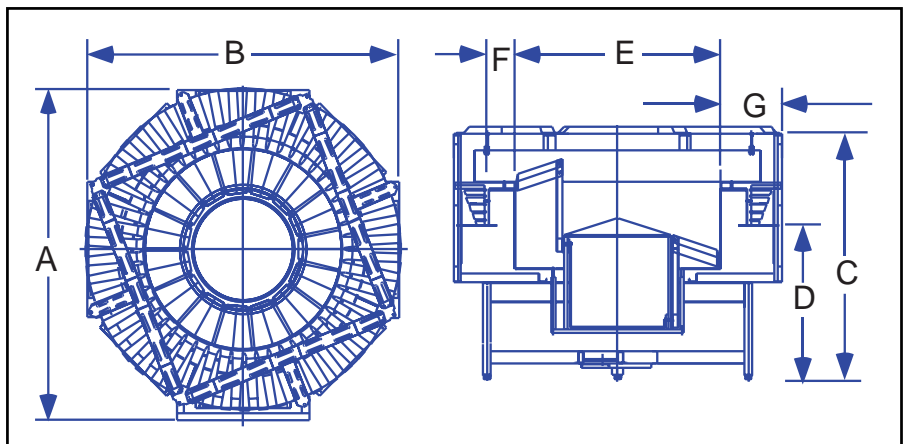

**We Can Handle It.**

Hoppmann Corporation strives to improve its products and reserves the right to change or discontinue specifications & designs shown in this brochure without notice and without incurring obligation. 06/05

**Your Local Representative:**

Automatic Feeder Company Inc.  
 921 Albion Avenue Schaumburg, IL 60193-4550  
 Phone: (847) 534-2300 Toll-Free: (888) 534-2340 Fax: (847) 534-2354  
 www.automaticfeeder.com Email: sales@automaticfeeder.com

