



FS-50-RD Centrifugal Feeder

Designed for Quiet, High Speed Feeding



Product Overview:

Hoppmann's standard FS-50 scallop feeder is designed to feed and orient bottles and other cylindrical parts with the use of urethane scallops. Parts are radially oriented and gently qualified in the scallop pockets by means of sweeps, wipers, pneumatic and/or electric devices depending on specific product characteristics. Oriented parts are discharged and carried away by various downstream in-line devices.

Product Specifications:

	ANSI	Metric
A. Overall Outside Square	78.51"	1994mm
B. Frame Height	48.50"	1232mm
C. Bowl Height	35.88"	911mm
D. Bowl Outside Diameter	56"	1422mm
E. Bowl Inside Diameter	47.75"	1213mm
F. Rim Width	4.13"	105mm
G. Bowl Depth	7.05"	179mm
H. Level Foot Adjustment	4.63" ± 2"	118mm ± 51mm

Standard Models:

Part Number	FS501RLDSA	FS501RLASA
Motor Style	DC	AC
Motor Voltage	90V	230/460V
Horsepower	3/4 hp	560 W

Required Accessories:

FS Series Scallop Kit FS50SCALXX
(includes segment plates and one of the following number of scallops: 36, 48, 54, 60, or 72).

Standard Features:

- All stainless steel construction
- FDA/USDA approved heavy gauge ABS plastic disc
- Teflon hard-coat finished aluminium bowl, predrilled for scallop mounting
- Air clutch
- Hinged polycarbonated cover with safety interlocks
- Backup ring
- Panel mount controller card

Available Options:

- Washdown motors
- Urethane scallop kit
- NEMA 1 encased controller

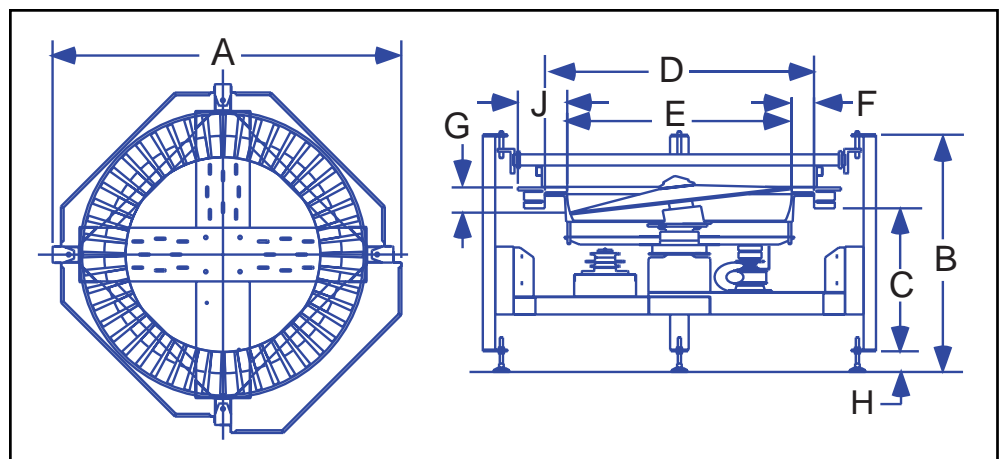

We Can Handle It.

Hoppmann Corporation strives to improve its products and reserves the right to change or discontinue specifications & designs shown in this brochure without notice and without incurring obligation. 06/05

Your Local Representative:

Automatic Feeder Company Inc.
921 Albion Avenue Schaumburg, IL 60193-4550
Phone: (847) 534-2300 Toll-Free: (888) 534-2340 Fax: (847) 534-2354
www.automaticfeeder.com Email: sales@automaticfeeder.com

**automatic
feeder
company** INC