



FT-15-RD Centrifugal Feeder
 Designed for Quiet, High Speed Feeding



Product Overview:

Hoppmann's standard FT-15 rigid disc centrifugal feeder is designed to feed a variety of products with its unique bowl design. Product is metered into the bowl and brought out to the bowl rim where a series of qualifiers gently orient the part for transfer to various downstream inline devices.

Product Specifications:

	<u>ANSI</u>	<u>Metric</u>
A. Outside Diameter	23"	585mm
B. Frame Height	15.75"	400mm
C. Discharge Height	13.22"	336mm
D. Bowl Outside Diameter	20.50"	521mm
E. Bowl Inside Diameter	16"	406mm
F. Rim Width	2.25"	57mm
G. Bowl Depth	2.69"	68mm

Standard Models:

Part Number	<u>FT151RLDSA</u>	<u>FT151RLASA</u>
Motor Style	DC	AC
Motor Voltage	90V	180V
Horsepower	1/5 hp	149 W

Required Accessories:

	<u>CW</u>	<u>CCW</u>
Square Frame		
Backup Ring	BUCWFT15SU	BUCCT15SU

Standard Features:

- All stainless steel construction
- Square tooling frame
- Teflon hard-coated flat disc
- Polyurethane foam bowl
- Panel mount controller card

Available Options:

- Polycarbonate covers
- Dual motor drive system
- Washdown motor(s)
- NEMA 1 encased controller
- Teflon hard-coated finished aluminium bowl
- Autoclave upgrade

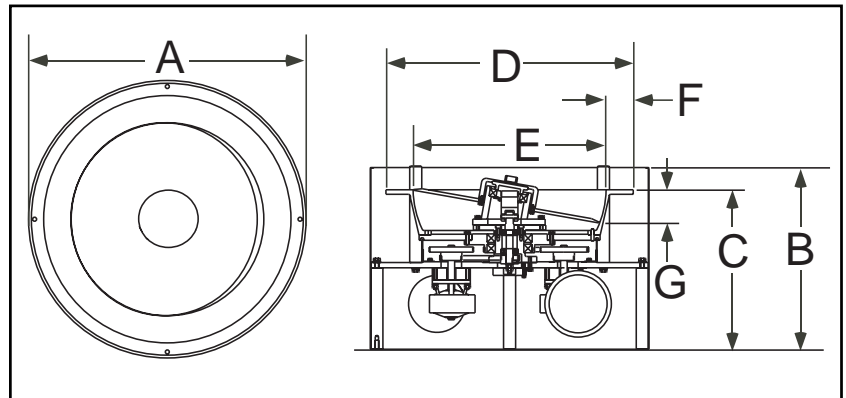

Hoppmann Corporation strives to improve its products and reserves the right to change or discontinue specifications & designs shown in this brochure without notice and without incurring obligation. 06/05

We Can Handle It.

Your Local Representative:

Automatic Feeder Company Inc.
 921 Albion Avenue Schaumburg, IL 60193-4550
 Phone: (847) 534-2300 Toll-Free: (888) 534-2340 Fax: (847) 534-2354
 www.automaticfeeder.com Email: sales@automaticfeeder.com

