



FTF-30-RD Centrifugal Feeder

Designed for Quiet, High Speed Feeding



Product Overview:

Hoppmann's standard FTF-30 rigid disc centrifugal feeder is designed to feed a variety of products in a food-grade environment with its unique bowl design. Product is metered into the bowl and brought out to the bowl rim where a series of qualifiers gently orient the part for transfer to various downstream inline devices.

Product Specifications:

	ANSI	Metric
A. Outside Diameter	40.21"	1021mm
B. Frame Height	22.79"	579mm
C. Discharge Height	17.51"	445mm
D. Bowl Outside Diameter	36.13"	918mm
E. Bowl Inside Diameter	28.79"	731mm
F. Rim Width	3.67"	93mm
G. Bowl Depth	5.65"	144mm
H. Level Foot Adjustment	3.97" ± 1"	101mm ± 25mm

Standard Features:

- All stainless steel construction
- Square tooling frame
- FDA approved ABS vacuum formed disc
- Teflon hard-coated finished aluminium bowl
- Panel mounted controller card
- Washdown motors and drive assembly

Standard Options:

- Polycarbonate covers
- Dual motor drive system

Standard Models:

Part Number	FT301RLDFA	FT301RLAFA
Motor Style	DC	AC
Motor Voltage	90V	230/460V
Horsepower	1/3 hp	249 W

Required Accessories:

	CW	CCW
Square Frame		
Backup Ring	BUCWFT30FU	BUCCFT30FU

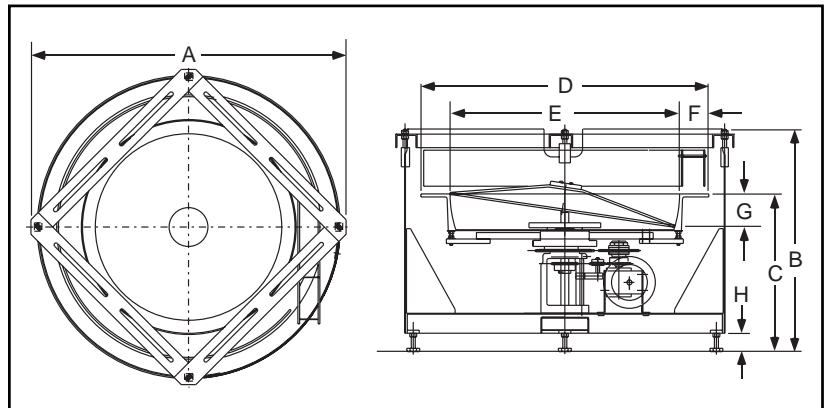

Hoppmann Corporation strives to improve its products and reserves the right to change or discontinue specifications & designs shown in this brochure without notice and without incurring obligation. 07/05

We Can Handle It.

Your Local Representative:

Automatic Feeder Company Inc.
921 Albion Avenue Schaumburg, IL 60193-4550
Phone: (847) 534-2300 Toll-Free: (888) 534-2340 Fax: (847) 534-2354
www.automaticfeeder.com Email: sales@automaticfeeder.com

**automatic
feeder
company** inc