



FTF-50-RD Centrifugal Feeder
 Designed for Quiet, High Speed Feeding



Product Overview:

Hoppmann's standard FTF-50 rigid disc centrifugal feeder is designed to feed a variety of products in a food-grade environment with its unique bowl design. Product is metered into the bowl and brought out to the bowl rim where a series of qualifiers gently orient the part for transfer to various downstream inline devices.

Product Specifications:

	<u>ANSI</u>	<u>Metric</u>
A. Outside Diameter	71"	1804mm
B. Frame Height	47" ± 1.5"	1194mm ± 40mm
C. Discharge Height	36" ± 2"	914mm ± 51mm
D. Bowl Outside Diameter	56"	1422mm
E. Bowl Inside Diameter	47.10"	1196mm
F. Rim Width	4.13"	105mm
G. Bowl Depth	7.10"	180mm
H. Level Foot Adjustment	3.00" ± 1"	76mm ± 25mm

Standard Models:

Part Number	<u>FT501RLDFA</u>	<u>FT501RLAFA</u>
Motor Style	DC	AC
Motor Voltage	90V	208-230/460V
Horsepower	3/4 hp	560 W

Standard Features:

- All stainless steel construction
- FDA approved ABS vacuum formed disc
- Teflon hard-coated finished aluminium bowl
- Panel mount controller card
- Washdown motor(s)

Available Options:

- Polycarbonate covers
- Dual motor drive system

Required Accessories:

Square Frame	<u>CW</u>	<u>CCW</u>
Backup Ring	BUCWFT50FU	BUCCT50FU

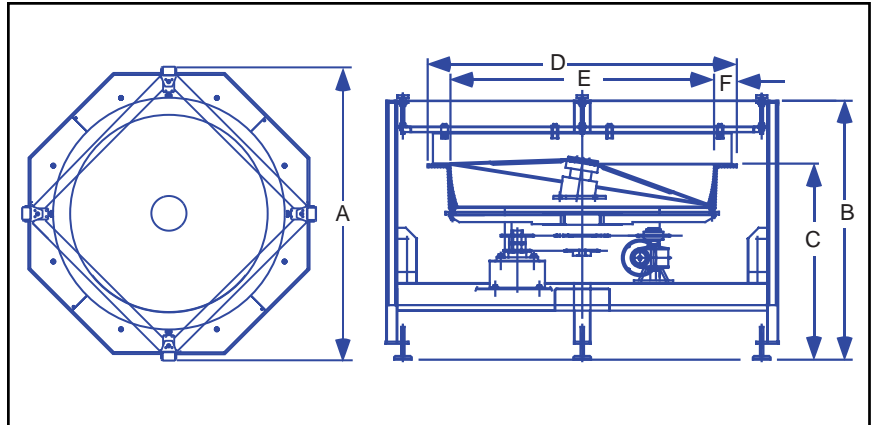

Hoppmann Corporation strives to improve its products and reserves the right to change or discontinue specifications & designs shown in this brochure without notice and without incurring obligation. 07/05

We Can Handle It.

Your Local Representative:

Automatic Feeder Company Inc.
 921 Albion Avenue Schaumburg, IL 60193-4550
 Phone: (847) 534-2300 Toll-Free: (888) 534-2340 Fax: (847) 534-2354
 www.automaticfeeder.com Email: sales@automaticfeeder.com

**automatic
 feeder
 company inc**