

XL pallet handling components

System information

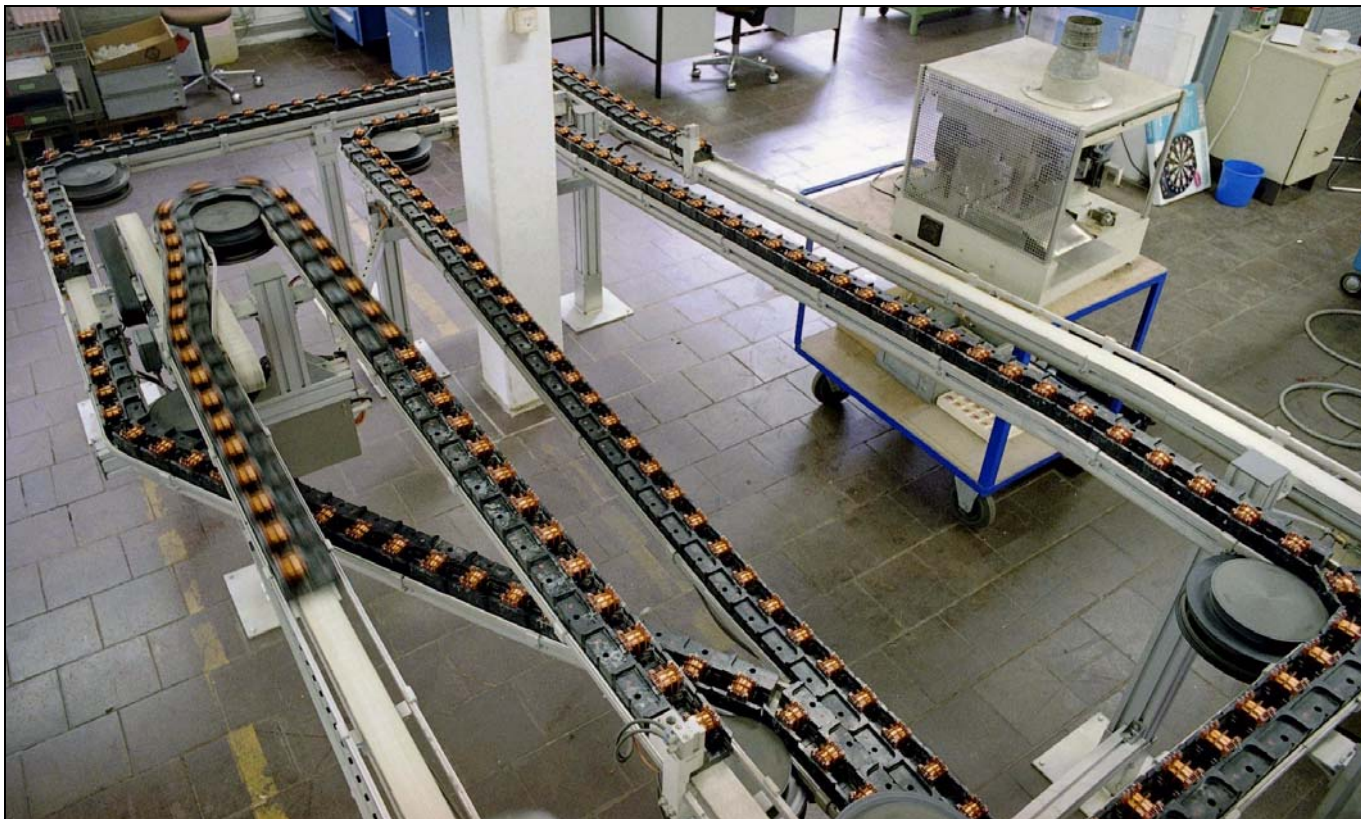

Pallet handling products for conveyor system XL

The pallet handling components for conveyor system XL are designed for loads up to 3 kg. The maximum size of the products on the pallets depends on the shape of the products and the location of their centre of gravity.

The XL pallet system includes a special flanged guide rail which prevents pallets from climbing when accumulated.

Guide rail brackets specifically designed for the pallet track width are available. The system also includes pre-bent guide rails for bends.

Application areas

Examples of application areas are transport and assembly of spark plugs, gear wheels, fuel injectors, hydraulic pistons, headlights, brake cylinders, cellular phones, and harddisk drives.

Technical characteristics

Pallet size.....	100 mm × 100 mm × 22 mm
Pallet weight.....	0,11 kg
Maximum load on pallet.	3,0 kg (including pallet and fixture)

P0
X45
XS
XL
XLP
X85
X85P
XH
XK
XKP
XB
GR
CS
XT
XC
XF
XD
FST
XMY
XLX
XMX
GRX
CSX
ELV
CTL
TR
APX
IDX

Pallet

Pallet 100×100

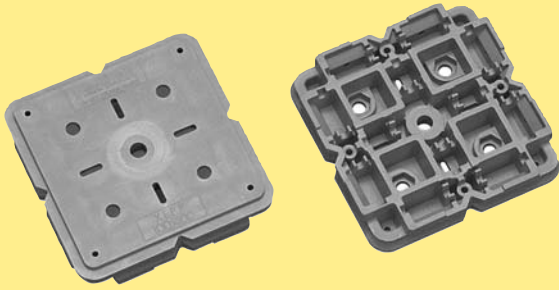

Pallet 100 mm × 100 mm

XLPP 100×100

Mineral reinforced PPE/PA.

Pallet weight: 0,11 kg. Max load on pallet: 3 kg.

See page 105 for detailed pallet dimensions

Pallet accessories

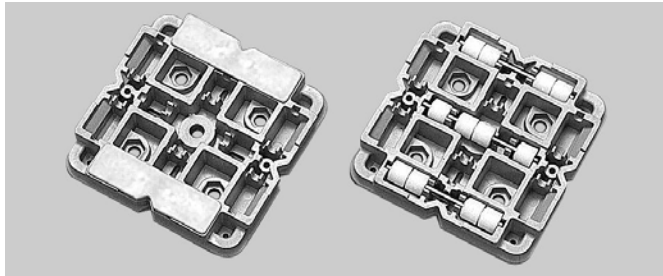

Shock absorber

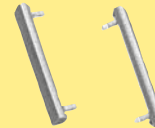

Shock absorber

3904052

Thermoplastic ethylene + polypropylene

1 shock absorber. 2 shock absorbers are needed for each pallet.

Slide block for pallet



Slide block for pallet

XLPS 67

Polyamide

1 slide block. 2 slide blocks are needed for each pallet.

Note. Must be ordered in multiples of 10

Initiator plate



Initiator plate

XLPL 30×20

Steel. Including screw.

1 or 2 initiator plates can be fitted to a pallet.

Note. Must be ordered in multiples of 25

Shaft and roller kit



Shaft and roller kit

3904055

Rollers: Polyacetal resin

Shaft: Stainless steel

Kit contains 3 shafts and 12 rollers. One kit is needed for each pallet.

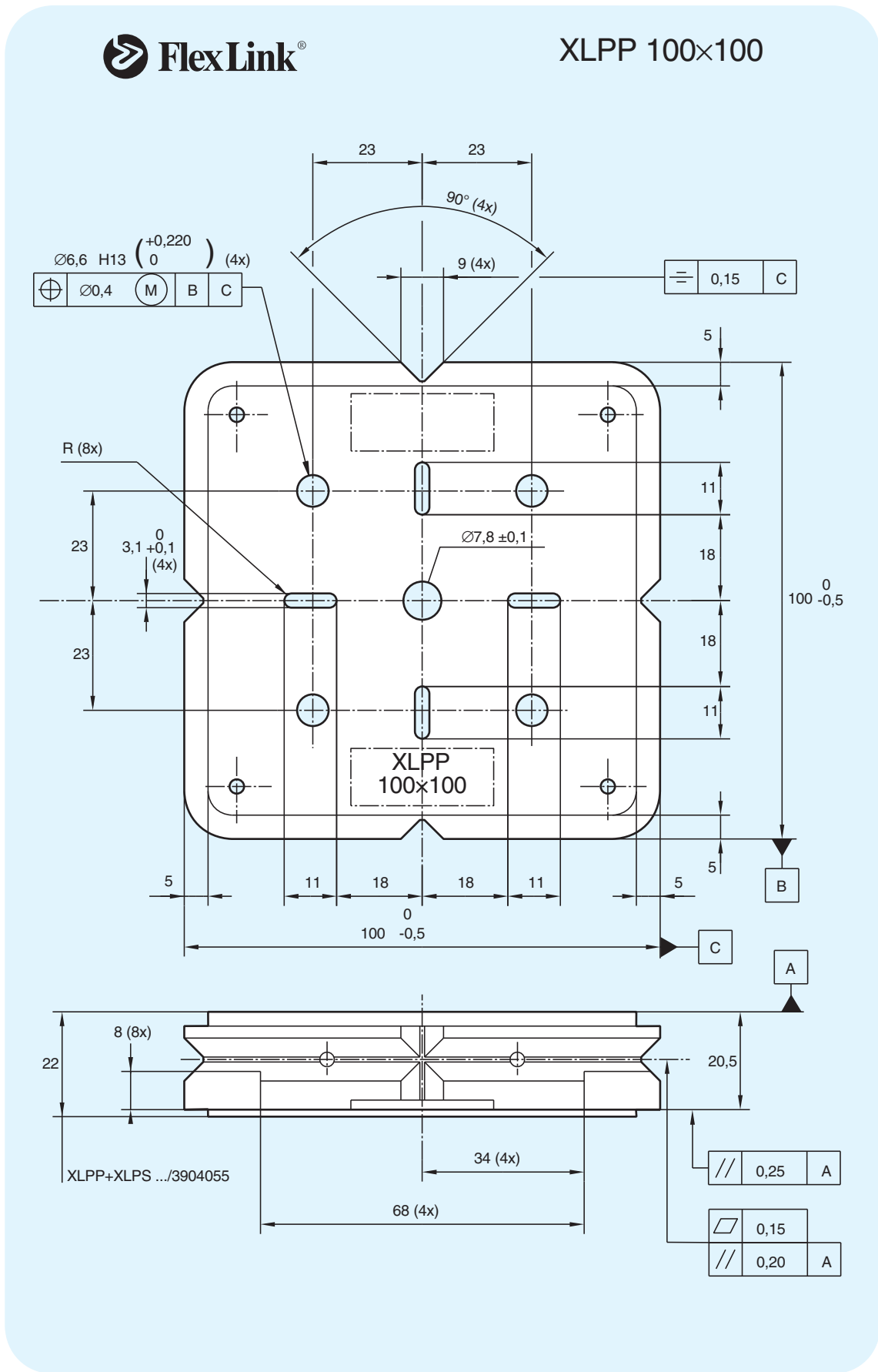

Guide rail

Straight guide rail

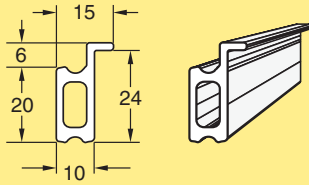

Guide rail for XL pallets
Length 3 m

XLRS 3x10 FL

Guide rails for pallets in 90° bends

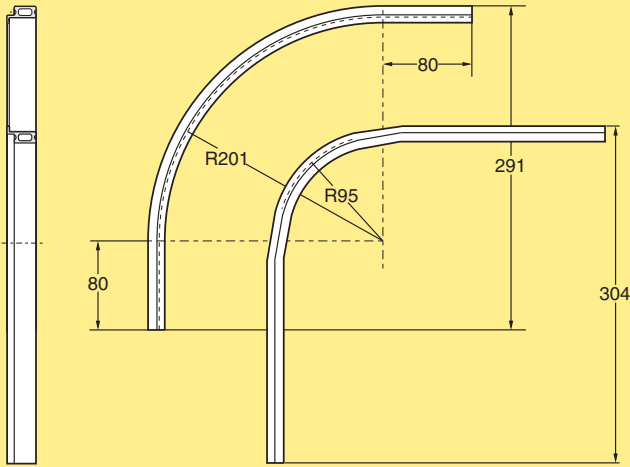

Outer guide rail for 90° bend
Inner guide rail for 90° bend

3904897
3905239

Guide rails for pallets in 180° bends

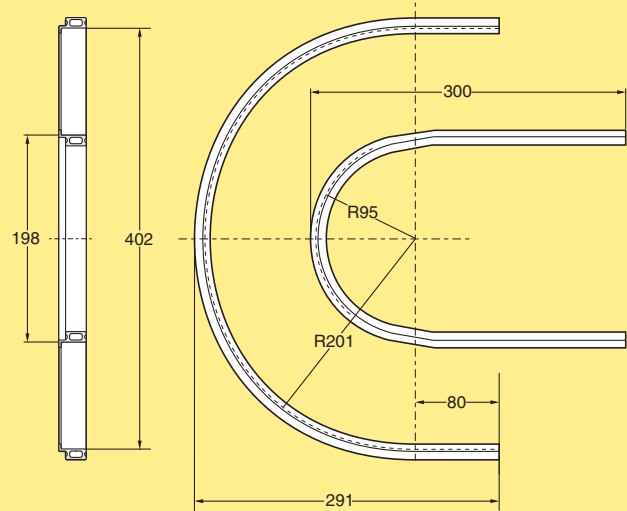

Outer guide rail for 180° bend
Inner guide rail for 180° bend

3904896
3905238

Guide rail bracket

Guide rail bracket

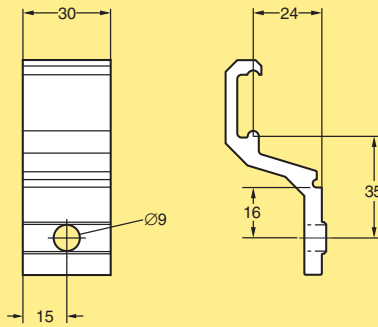

Guide rail bracket for XL pallets **XLRB 29x36**

To be used with 10 mm wide guide rail. Use spring pins XLAP 28 to secure the guide rails to the brackets.

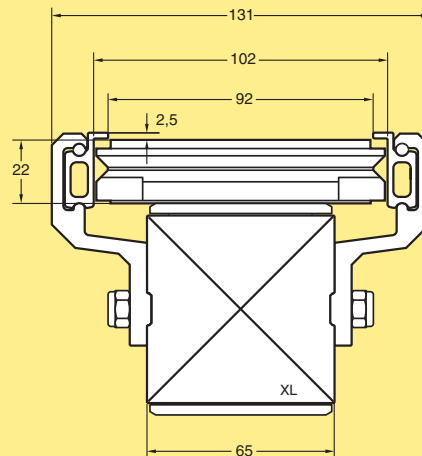

Pallet locating station

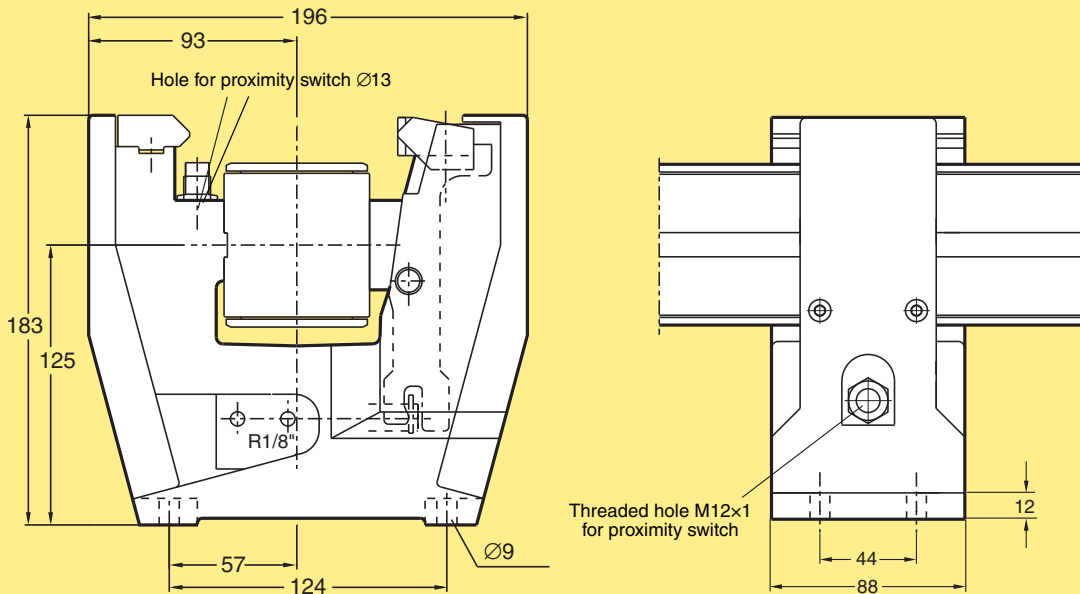

Pneumatic locating station **XLPX 100 A**

Frame: cast aluminium. Horizontal and cross wedges: hardened steel.
Cylinder connection 6 mm

Locating accuracy: $\pm 0,1$ mm. Locating force at 0,6 MPa: 460 N. Max vertical force including pallet weight: 300 N.

T-bolts and nuts for mounting the locating station to the conveyor beam are included. Mounting hardware for connection to a support structure must be ordered separately.

The proximity sensors ($\varnothing 12$ mm, not supplied by FlexLink Systems) must have a minimum effective sensing distance of 2,5 mm to the initiating surface (aluminium).

Example: the effective sensing distance for SICK (IM12 sensing range 8 mm) is 5,18 mm. This is calculated as follows: $8 \text{ mm} \times 0,81^* \times 0,45^{**} = 2,92 \text{ mm}$. (*Useful sensing range = $0,81 \times$ nominal sensing range, **Reduction factor for aluminium.)

Locating station with pallet and stop cylinder

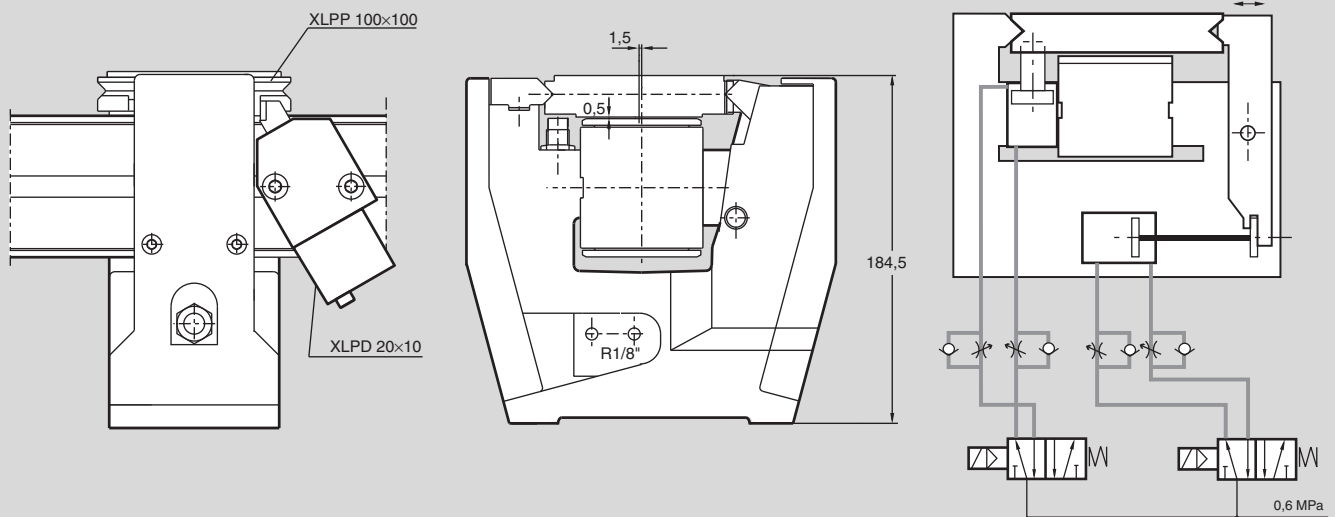

Pallet stop cylinder

Pallet stop cylinder

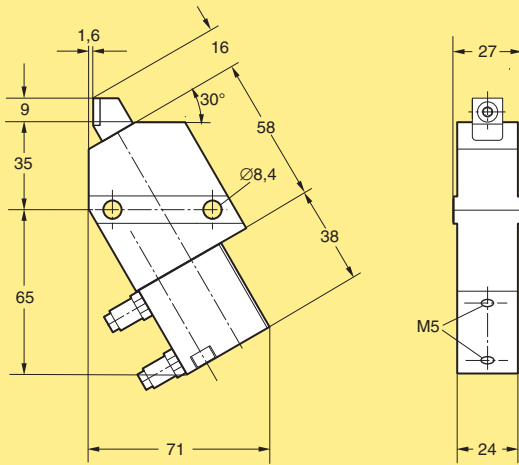

Pneumatic stop cylinder
Double-actuated

XLPD 20x10

Housing, cover: anodized aluminium.
Plunger: polyamide with steel top.
Stroke: 10 mm. Theoretical force at 0,6 MPa: 130 N (minus direction). For use with cylinder position sensors. Including Ø6 pipe connections and the necessary mounting hardware.
The pneumatic stop includes an integrated spring for stop out if air supply is cut off.

The diagram shows the maximum permissible weight of a group of pallets (product weight + pallet weight) that the stop cylinder is capable of stopping, as a function of the conveyor speed.

Bracket for proximity switch

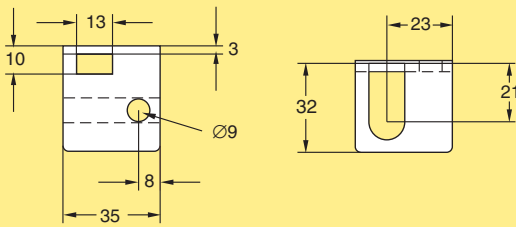

Bracket for proximity switch
Ø12 mm

XMPB 12

Anodized aluminium

Pallet stop cylinder on conveyor beam

