



Chain cleaning module for wet cleaning with drying function

The chain cleaning module for wet cleaning with drying function is designed to run continuously when working with production lines that have a high degree of product spillage. The result is a cleaner and dryer chain that allows longer production runs without the need for CIP or routine maintenance.

BENEFITS

The chain cleaner prevents product build up on the chain and allows continuous fault free running of the line without the need to stop the conveyor and remove the chain to clean by hand. Supplied as a complete unit the washer/dryer can quickly be integrated into new conveyor lines or upgraded to existing conveyor lines in order to improve performance and reliability.

STANDARD FEATURES

- **Robust** – the system is robust and designed to operate within harsh environment where spillages on the conveyor are highly likely
- **Simple installation** – mount to conveyors using standard fittings
- **Compact** – the unit takes up the smallest footprint possible
- **Clean** – clean design with sloping faces and minimum areas for fluid or dirt to build up
- **Safe** – fully guarded design.

Chain cleaning module for wet cleaning with drying function

System information

The washing/dryer unit is available for aluminium conveyor systems XS, XL, X65, X85, XH and XK, and stainless systems XLX and X85X



Operating requirements

Water supply

Connection of water/cleaning system is made by G 1/2" internal thread connection. Max/Min flow rate required is 11–13,5 l/min

Air attachment

Connection of air system is made by G 1/2" internal thread connection. Air system requirements 6 Bar with a flow rate of 200 m³/h.

Drainage/ Drying Vacuum

Vacuum attachment is made by Ø32 hose connection. Vacuum requirements are 23,5 kPa minimum with a vacuum of 2x56 l/second.

Technical characteristics

Minimum top of chain height	700 mm
Maximum conveyor length	20 m
Maximum conveyor speed	50 m/min

Ordering information

Chain cleaning module for wet cleaning with drying function

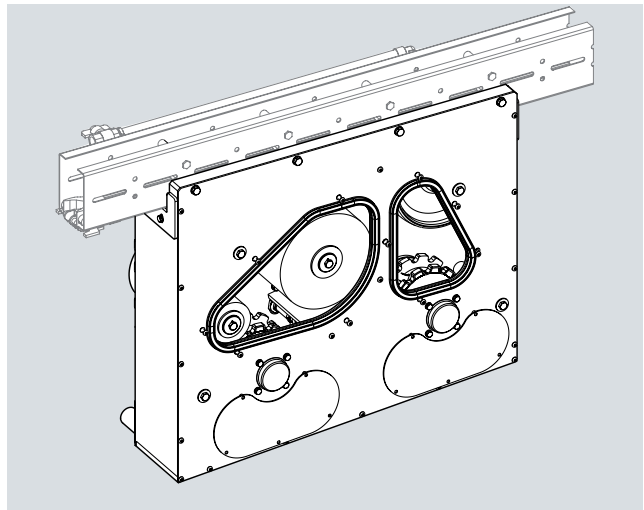

Unit XS	8042679
Unit XL	8042663
Unit XLX	8042664
Unit X65	8044104
Unit X85	8042665
Unit X85X	8042666
Unit XH	8042667
Unit XK	8042668

Note. 1 m long beam section is included. The chain cleaning module cannot be used with an enclosed or guided type of conveyor drive unit.

Spare parts

See separate document 5742EN-1 Spare parts Chain Cleaning modules