

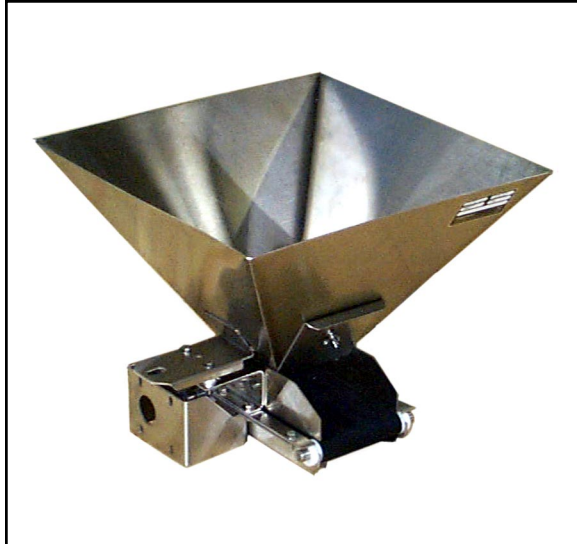

LB-01 Live Bottom Prefeeder
 Designed for Overhead Parts Loading



Product Overview:

Hoppmann's standard LB-01 overhead prefeeder is specially designed to handle small parts and is engineered to interface directly with smaller style parts feeders. A variable speed motor drives the belt at a speed of 23.00 inches per minute.

Product Specifications:

	<u>ANSI</u>	<u>Metric</u>
A. Hopper Width and Length	18" x 18"	457 x 457mm
B. Overall Height	15.25"	387mm
C. Discharge Height	2" ± 1"	51mm ± 25mm
D. Belt Width	5"	127mm

Standard Models:

Part Number	<u>LB01XXXDSA</u>
Motor Style	DC
Motor Voltage	90V
Horsepower	1/30 hp/25 W
Total Equipment Weight	35 lbs./16 kg
Hopper Capacity	1 ft ³ /28.32 liters

Standard Features:

- All stainless steel construction
- Durable reinforced black neoprene belt with fiberglass cord
- Feeder mounting brackets
- Panel mount controller card
- Mechanical style level sensor mounting kit – proximity sensor not included (P/N LEVSENPKG1)

Available Options:

- Continuous welded seams
- Hopper covers
- Tan neoprene USDA/FDA dry contact food belt with fiberglass cord
- NEMA 1 encased controller

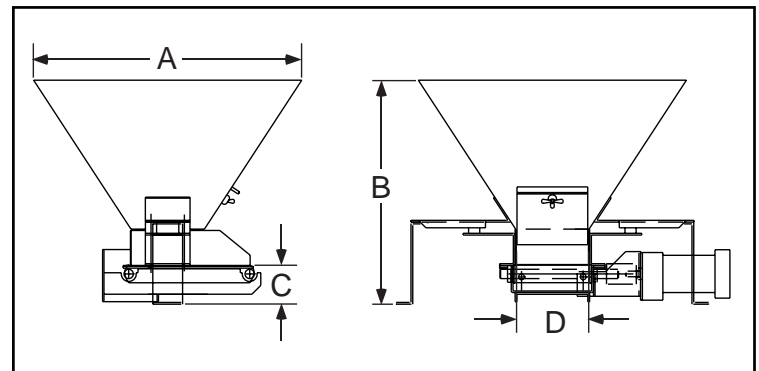

Hoppmann Corporation strives to improve its products and reserves the right to change or discontinue specifications & designs shown in this brochure without notice and without incurring obligation. 06/05

We Can Handle It.

Your Local Representative:

Automatic Feeder Company Inc.
 921 Albion Avenue Schaumburg, IL 60193-4550
 Phone: (847) 534-2300 Toll-Free: (888) 534-2340 Fax: (847) 534-2354
 www.automaticfeeder.com Email: sales@automaticfeeder.com

**automatic
 feeder
 company** inc