

WB-6 Wide Belt Prefeeder



Product Overview:

Shibuya Hoppmann's WB-6 prefeeder is specially designed to handle fragile parts. Two independent variable speed drives and a standard level sensor ensures gentle product metering. Product drops from the upper belt to the lower belt where it is pulled away at a faster rate to assist in part separation and de-tangling. **Note: Controllers and mechanical level sensors are not supplied with this unit.**

Part Number	WB06XXXDSA	WB06XXXASA
Motor Style	DC	AC
Motor Voltage	90V	220/380V
Upper Belt Horsepower	1/8hp	1/2hp
Lower Belt Horsepower	1/30hp	1/4hp
Total Equipment Weight	650 lbs.	295 kg
Supply Hopper Capacity	6 ft ³	170 liters

Standard Features:

- ✓ Stainless steel construction
- ✓ Adjustable feed angle
- ✓ Sensor controlled dual belt metering system
- ✓ FDA/USDA approved white buna-n/polyester polyflake endless belting (upper belt)
- ✓ Durable reinforced black neoprene belt with fiberglass cord (lower belt)

Available Options:

- ✓ Continuous welded hopper seams
- ✓ Washdown motors
- ✓ NEMA 1 encased controller
- ✓ Hopper covers
- ✓ Casters

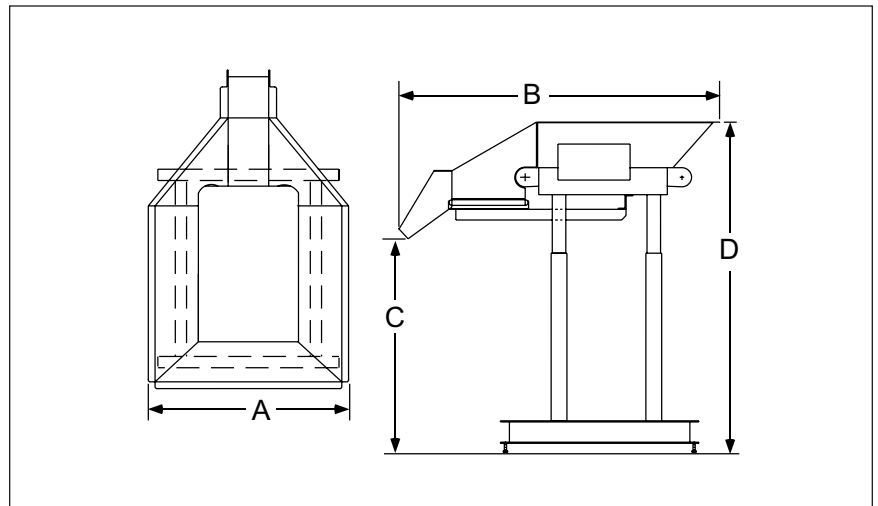

Product Specifications	ANSI	Metric
A Overall Width	51"	1295mm
B Overall Length	72"	1829mm
C Dump Height (Adjustable)	48" ± 10"	1219 ± 254mm
D Load Height (Adjustable)	74" ± 10"	1880 ± 254mm
E Angle of Feed	0° - 11°	0° - 11°

Shibuya Hoppmann Corporation strives to improve its products and reserves the right to change or discontinue specifications & designs shown in this brochure without notice and without incurring obligation. Revised: 05/10.

**automatic
feeder
company** inc

Your Local Representative:

Automatic Feeder Company Inc.

921 Albion Avenue Schaumburg, IL 60193-4550

Phone: (847) 534-2300 Toll-Free: (888) 534-2340 Fax: (847) 534-2354

www.automaticfeeder.com Email: sales@automaticfeeder.com



Shibuya Hoppmann

INTEGRATION THROUGH INNOVATION